

Medium Size Snap-In Receptacle

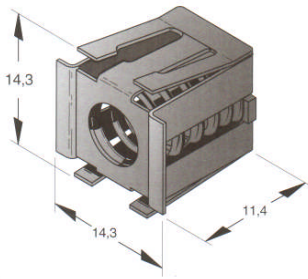

- Housing: 301 stainless steel, natural.
- Receptacle: 1010 steel, case hardened and zinc plated with chromate plus sealer
- Spring: 302 stainless steel, passivated
- Retainer: 301 stainless steel, natural

► For installation tool order
Part No: 29-8125-309



Adjustment Formula

To enter Stud Selection Table calculate:

Outer Panel Thickness + 5.08
but use Total Material Thickness
column

Part No: 82-35-309-56

Installation Tool



southco®

P/No: 29-8125-309

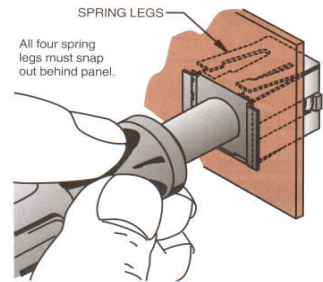
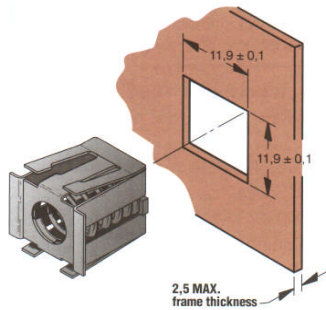

southco®

Medium Size Receptacle For Ultrasonic Installation In Thermoplastics

P/No: 82-35-310-55

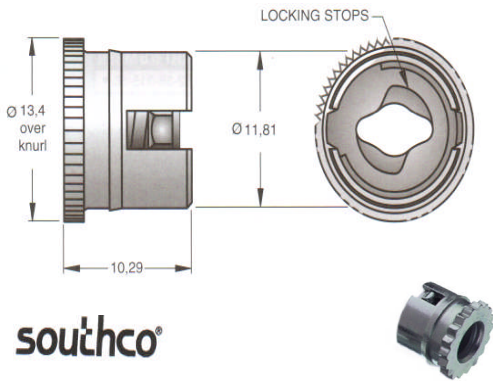

southco®

Installation

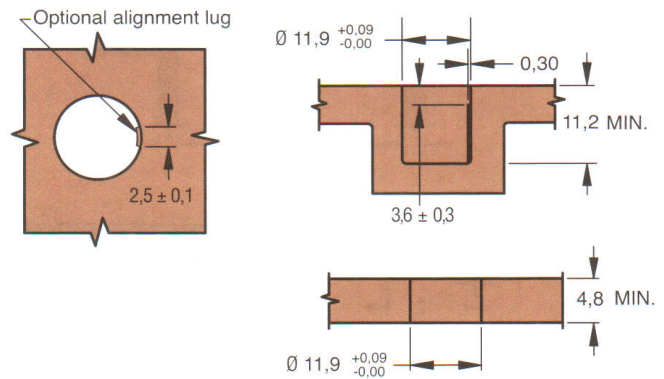

- Minimise residual stress
 - Increased pull-out resistance
 - Increased torque-out resistance
- Material:-
- Receptacle: 1010 steel, case hardened and zinc plate, chromate plus sealer
 - Shell: Low carbon steel, zinc plate, chromate plus sealer
 - Spring: 302 stainless steel, zinc immersion coating
 - Retainer: 302 stainless steel, zinc plate, chromate plus sealer

Method A

Horn recess receptacle to a 0.5 depth

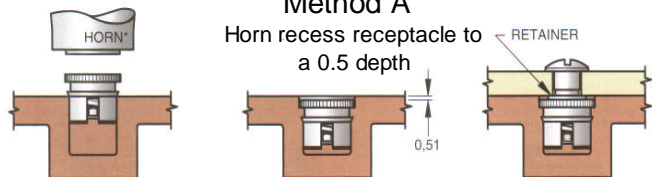

Method B

Horn installs receptacle flush with surface

