

Medium Size Leaf Spring Receptacle, **Weld Style**

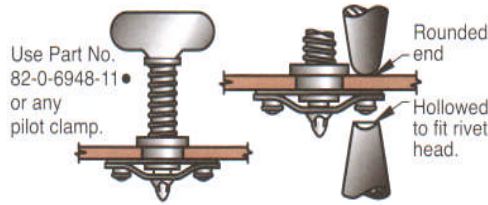
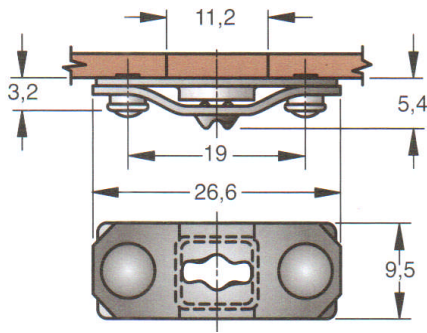

- Type 1064 DACROTIZED steel spring
- Type 1010 DACROTIZED steel base
- weld studs are steel copper plate

To enter stud Selection Table determine your

**SPRING MUST FLOAT FREELY AS BEFORE RIVETING.**

**Part No: 82-35-303-15**

**southco®**

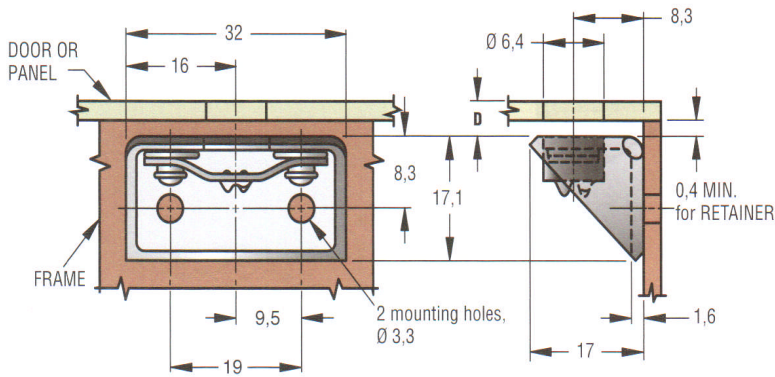

- Material:1064 DACROTIZED steel spring
- Material:1010 DACROTIZED steel angle bracket, zinc plated with chromate plus sealer
- DACROTIZED steel eyelet
- Two .130" diameter mounting holes

**Adjustment Formula**

To enter Stud Selection Table calculate:  $D+1.5 (.060")$  and use Total Material Thickness column.



**P/No:82-0-22542-11**

**southco®**

Medium Size Vibration Isolating Receptacle

- Black neoprene boss dampens vibration
- Type 1050-1070 steel receptacle, zinc plated with chromate plus sealer
- Type 6061 aluminium plate with zinc chromate finish
- Two .098" diameter mounting hole



To enter stud Selection Table determine your Outer Panel Thickness

**P/No: 82-35-306-10**

**southco®**

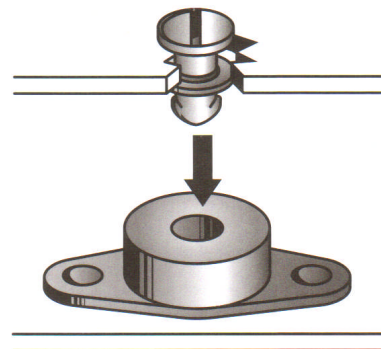
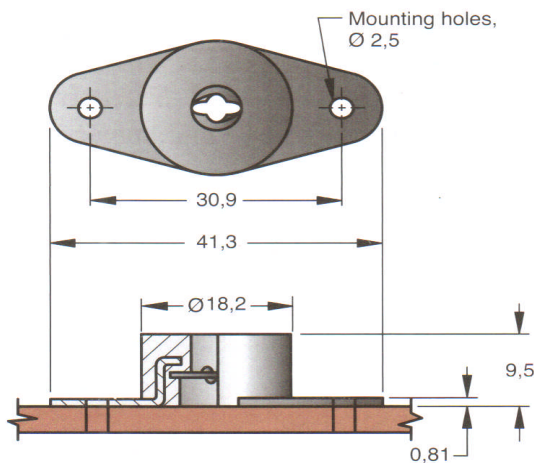

**southco®**